

CASE
CONSTRUCTION

F-SERIES COMPACT WHEEL LOADERS



PERFECT IN EVERY MISSION

F-SERIES COMPACT WHEEL LOADERS



**CASE,
MORE THAN 170 YEARS OF INNOVATION**
A long history of industry firsts

- **1842:** Case is founded.
- **1869:** First Case portable steam engine - road construction is born.
- **1957:** The first factory - integrated loader/backhoe in the world: a Case industry first.
- **1958:** The first Case 4-WD wheel loader, the W9.
- **1992:** Case expands its wheel loader range with 21B, 121B, 221B and 321B models.
- **1998:** Ride control on loader backhoes and skid steer loader: another Case first.
- **2001:** The exclusive Cooling Cube in Case wheel loaders means clean engine, reliability and massive bucket payloads.
- **2005:** The E-Series compliant with Tier 3 emissions regulations and with High Travel Speed option is launched.



PERFECT IN EVERY MISSION



LOW EMISSIONS

FPT, in-house advanced engine technology

Case equipment features the advanced in-house engine technology developed by sister company FPT Industrial that pioneered low emissions, high efficiency solutions for on- and off-road applications. With a broad portfolio of technologies and products, FPT brings to Case customers the competitive advantage of powertrain technologies that reliably delivers high performance with low operating costs – proven technologies from a global engine manufacturer that produces as many as 600,000 engines a year.

- 3.4 liter 4-cylinder Turbocharged Multiple Injection High Pressure Common Rail Engine with Waste Gate for optimum turbo pressure stability
- Tier 4 final / EU Stage IIIB compliant using **Maintenance Free** Technology:
 - A Diesel Oxidation Catalyst (DOC) that reduces the quantity of Particulate Matters (PM)
 - A PM-Catalyst that traps residual PM



Model	21F	121F	221F	321F
Power	58 hp / 43 kW	64 hp / 48 kW	74 hp / 55 kW	74 hp / 55 kW
Torque	251 N.m	255 N.m	308 N.m	308 N.m

12 GOOD REASONS TO USE IT



LOW CAB PROFILE

- Easy transport on truck,
quick access to the cab
- 21F and 121F: 2.46 m
 - 221F: 2.63 m
 - 321F: 2.68 m



COMFORT CAB

- 10 air vents ensure perfect climate control in all seasons
- Control all functions from the joystick



AUTO-RIDE CONTROL

Ride Control, activated only when needed,
over 7 km/h prevents arm bouncing.



HIGH PAYLOAD

- From 1,9 t up to 2,5 t tipping load
- Auto-Ride Control optimizes bucket retention



FAST ATTACHMENT CHANGE OVER

- Hydraulic coupler controlled from the all-in-one joystick
- Depressurized push-pull connectors



SHORT TURNING RADIUS

Makes your day-to-day job easier
when working in tight spaces.



HIGH VERSATILITY

Easy asphalt planing, snow blowing, brooming, compacting and much more with:

- 1 or 2 auxiliary hydraulic circuit
- Creep speed: max flow at constant low speed
- High flow option on 221F and 321F
- The wide offering of Case attachments



SUPERIOR CAB SAFETY

Keeps you protected in case the machine rolls over or a 200 kg object falls from 5m high (ROPS and FOPS level II).



LOW EMISSIONS

- EU Stage IIIB compliant
- No particulate filter
- No fuel injectors in the exhaust



FAST TRAVELLING

- Engage Turtle/Rabbit speed under load
- 221F and 321F are available in High Travel Speed (HTS) version: 33 km/h



GREATER STABILITY

- Oscillating rear axle
- Easier levelling on rough terrains



EASY CAB ACCESS

Step in and out of the cab in a second.



F-SERIES COMPACT WHEEL LOADERS



GREATER STABILITY

Oscillating rear axle

The combination of the articulated joint and the rear oscillating axle reduces maximum cab oscillation by 50% or more.



MILLIMETRIC CONTROL

Inch and brake pedal

It progressively disengages the transmission during the decelerating phase and progressively engages the brakes.

PERFECT IN EVERY MISSION



HIGH PAYLOAD

Handle Heavier pallets



LOW CAB PROFILE

Take the shortest path

No waste of time with the reduced cab height:

- 21F and 121F: 2.49 m
- 221F and 321F: 2.63 m
- 321F and 321F: 2.68 m

You can always take the shortest path from point A to point B - in indoor jobs or when transporting on a truck.



SUPERIOR DUMP HEIGHT

Centred and higher loading

The superior hinge pin height and the Case “banana” arms make it easy to load at the centre of the trailer without touching the edge with the arms.

F-SERIES COMPACT WHEEL LOADERS



HIGH VERSATILITY

Ready for every attachment



FAST ATTACHMENT CHANGE OVER

Plug and unplug your attachment in a few seconds

With the depressurized push-pull connectors you will never need hand tools to swap your attachments

Front electrical socket

For multi-functioning or special attachments

Standard flow or high flow

- Standard Flow (Max pressure: 230 bar):
 - 21F-121F: 67 lpm @ 2500 rpm
 - 221F-321F: 85 lpm @ 2500 rpm
- The High Flow package is available on 221F-321F:
 - 130 lpm @ 2500 rpm

High Flow option always comes as part of a package including Creep Speed, Front electrical socket and Return Depressurized Drain.

PERFECT IN EVERY MISSION



COMFORT CAB

Work around the clock



ALL-IN-ONE Joystick

*Adjustable
wrist rest*

10 air vents

*Tilting adjustment
of the steering wheel*

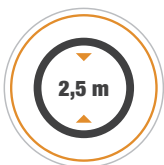

SUPERIOR CAB SAFETY

Cab structure: rops and fops level 2 come as standard

Designed to protect the operator in case the machine rolls over a 227 kg rock falls from 5 meters height on the roof.



EASY CAB ACCESS

Easy entrance

With low cab floor and wide steps.

If you want even more

The Deluxe Option includes an additional storage compartment under you left hand, storage spaces around the seat and height adjustment of the steering wheel.

F-SERIES COMPACT WHEEL LOADERS

GENERAL DIMENSIONS

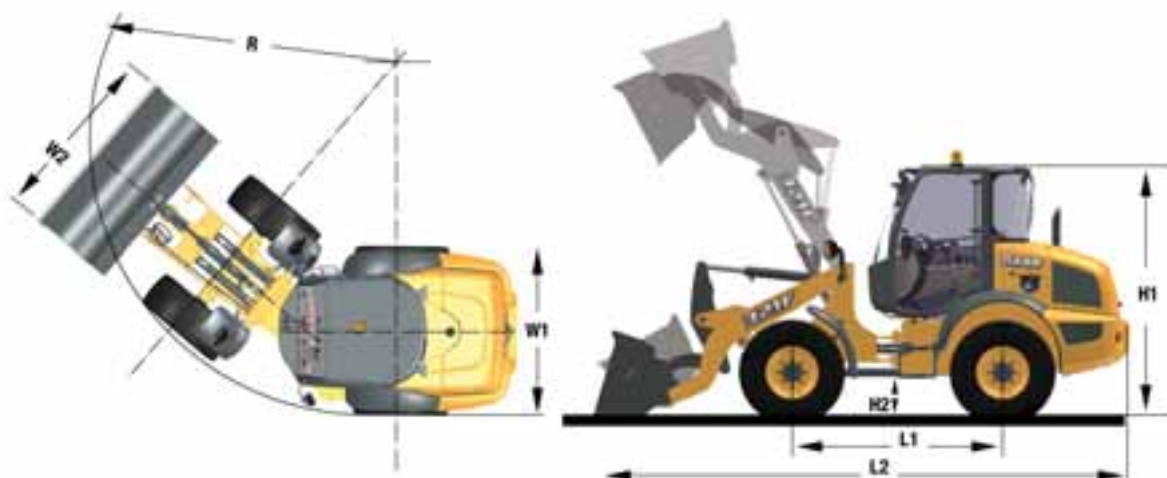

	21F	121F	221F	321F
H1	2.46 m	2.46 m	2.63 m	2.68 m
H2	45 cm	45 cm	44 cm	49 cm
W1	1.74 m	1.74 m	1.80 m	1.86 m
W2	1.90 m	2.05 m	2.05 m	2.10 m
L1	2.08 m	2.08 m	2.22 m	2.23 m
R	3.72 m	3.72 m	3.99 m	3.99 m

TRANSMISSION

Hydrostatic 4-wheel Drive Transmission _____ Travel speed is proportional to the pressure on the throttle.

Speed with standard tyres

Operating speed range _____ 0–5 km/h

Travel speed range _____ 0–20 km/h

Optional High Travel Speed _____ 33 km/h

(upon request on 221F and 321F)

“Inch & Brake” Pedal

Power transfer from the transmission to the bucket hydraulics at constant rpm. Optimum speed control at low speed.

Optional Creep Speed (upon request on 221F and 321F):

Set and adjust travel speed in the 1–5.5 km/h range, adjust engine rpm for hand-free asphalt planing, snow blowing, brooming.

DIFFERENTIAL CHOICE

Limited slip front & rear (all models) or Front & rear open diff (21F & 121F) or open with 100% lock on front and rear differentials (221F & 321F)

TYRES

Standard

21F/121F _____ 12.5–18

221F _____ 12.5–20

321F _____ 14.5–20

More special tyres upon request

BRAKES

Standard brakes _____ disc brake.

Located in hubs for 221F/321F, centre mounted for 21F/121F

Parking brakes _____ disc brake on transmission shaft

STEERING

Fully hydraulic center pivot steering.

Front and rear wheels follow the same track.

Steering angle of 40° to each side.

Emergency steering function.

ELECTRICAL SYSTEM

Voltage _____ 12 V

Battery _____ 95 A.h

Alternator _____ 120 A.h

CAPACITIES

Diesel _____ 87 l

Engine oil _____ 7 l

Cooling liquid _____ 16 l

Total hydraulic oil _____ 57 l

Front axle _____ 9 l

Rear axle _____ 12 l

HYDRAULICS

Gear pump for loading and steering hydraulics

Priority valve favouring steering hydraulics

3rd or 4th functions are proportionally controlled by the All-in-one

Joystick with , Flow memory button as standard.

Standard Flow

21F-121F _____ 67 lpm @ 2500 rpm

221F-321F _____ 85 lpm @ 2500 rpm

High Flow package

available upon request on

221F-321F _____ 130 lpm @ 2500 rpm

NOISE AND VIBRATIONS

External - Guaranteed acoustic power-level LWA (1) _____ 101 dB

Cab interior - Sound Pressure Level (2) 21F - 121F: _____ 71 dB

221F - 321F: _____ 72 dB

Hand- / arm- / body -vibration (3) _____ < 2.5 / 0.5 m/s²

(1) According to 2000/14/EG & appendixes.

(2) According to ISO 6396.

(3) According to ISO 8041

EMISSIONS

Nox + HC _____ 4,5 g/kW/h

CO _____ 0,10 g/kW/h

PM _____ 0,02 g/kW/h

PERFECT IN EVERY MISSION

EASY PALLET LOADING

Linkage: mechanical self-levelling on XT and z-bar



XT is the best linkage for pallet handling. Visibility on the pallet is the best with one lifting cylinder only and payload is optimum



Z-bar is the most versatile linkage type. It offers more breakout force thanks to the 2 lifting cylinders and a higher dump height.

SPECIFICATIONS WITH FORKS

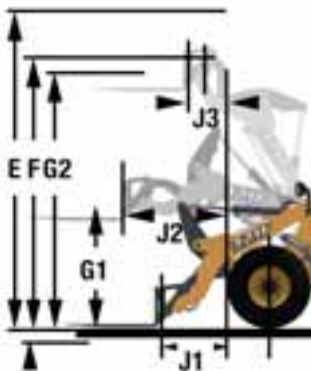

	21F		121F		221F	321F
	Z-BAR	XT	Z-BAR	XT	Z-BAR	Z-BAR
Tipping load straight	2,8 t	3,0 t	3,0 t	3,2 t	3,1 t	3,6 t
Tipping load at full turn	2,4 t	2,6 t	2,6 t	2,8 t	2,7 t	3,0 t
Payload @80%	1,9 t	2,1 t	2,1 t	2,2 t	2,2 t	2,5 t
F Max overall height	3,48 m	3,63 m	3,53 m	3,65 m	3,63 m	3,73 m
B Hinge pin height	3,14 m	3,11 m	3,18 m	3,13 m	3,29 m	3,40 m
G2 Max fork height	2,90 m	2,96 m	2,95 m	2,97 m	3,08 m	3,19 m
G1 Forks height @ max reach	1,27 m	1,34 m	1,27 m	1,34 m	1,34 m	1,39 m
J1 Reach @ ground level	0,94 m	0,77 m	1,01 m	0,80 m	0,99 m	0,99 cm
J2 Max Reach	1,35 m	1,26 m	1,41 m	1,27 m	1,43 m	1,43 cm
J3 Reach @ max height	0,59 m	0,46 m	0,63 m	0,47 m	0,61 m	0,61 m
Operating weight	4910 kg	5020 kg	5090 kg	5310 kg	5559 kg	6060 kg

SPECIFICATIONS WITH BUCKET

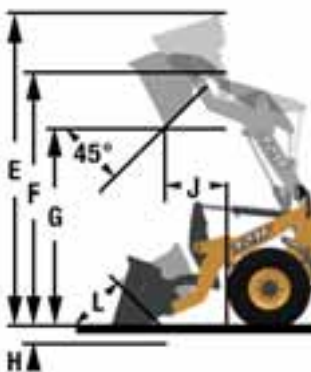

	21F		121F		221F	321F
	Z-BAR	XT	Z-BAR	XT	Z-BAR	Z-BAR
Bucket Volume (SAE)	0,7-1,0 m ³		0,9-1,1 m ³		1,0-1,2 m ³	1,1-1,2 m ³
Breakout Force	0,7-1,0 m ³		0,9-1,1 m ³		1,0-1,2 m ³	1,1-1,2 m ³
Max operating weight	5,4 t	5,3 t	5,7 t	5,5 t	6,0 t	6,5 t
L2 Length with bucket	5,28 m	5,23 m	5,39 m	5,33 m	5,62 m	5,68 m
A Max bucket height	3,14 m	3,94 m	3,18 m	4,09 m	3,29 m	3,40 m
B Hinge pin height	3,14 m	3,11 m	3,18 m	3,13 m	3,29 m	3,40 m
C Dump height @45°	2,49 m	2,34 m	2,52 m	2,35 m	2,60 m	2,69 m
D Dig Depth	7,3 cm	13 cm	12 cm	14 cm	10 cm	8,4 cm
E Reach at full height	77 cm	71 cm	83 cm	74 cm	85 cm	85 cm
Operating mass	5015 kg	5115 kg	5208 kg	5423 kg	5694 kg	6195 kg



F-SERIES COMPACT WHEEL LOADERS

CASE CONSTRUCTION EQUIPMENT CONTACT INFORMATION

CNH UK LTD
Unit 4,
Hayfield Lane Business Park,
Field Lane, Auckley,
Doncaster, DN9 3FL
UNITED KINGDOM
Tel: 00800-2273-7373
Fax +44 (0) 1302 802829

CNH INDUSTRIAL FRANCE, S.A.
16-18 Rue des Rochettes
91150 - Morigny-Champigny
FRANCE
Tel: +33 (0) 1 60 80 74 80

**CNH INDUSTRIAL
DEUTSCHLAND GMBH**
Case Baumaschinen
Benzstr.1-3
D-74076 Heilbronn
GERMANY - DEUTSCHLAND
Tel: +49 (0) 7131 6449 0
Fax +49 (0) 7131 6449 181

**CNH INDUSTRIAL
MAQUINARIA SPAIN, S.A.**
Avda. José Gárate, 11
28823 Coslada (Madrid)
SPAIN - ESPAÑA
Tel: +34 91 660 38 00
Fax: +34 91 660 38 18

CNH INDUSTRIAL ITALIA SPA
Strada di Settimo, 323
10099 San Mauro Torinese (TO)
ITALY - ITALIA
Tel: 800 2273 7373

NOTE: Standard and optional fittings can vary according to the demands and specific regulations of each country. The illustrations may include optional rather than standard fittings - consult your Case dealer. Furthermore, CNH Industrial reserves the right to modify machine specifications without incurring any obligation relating to such changes.

Conforms to directive 2006/42/EC



CASE Customer
Assistance
00800-2273-7373

The call is free from a land line.
Check in advance with your Mobile Operator
if you will be charged.

www.casece.com